



Luxcontrol^{SA}
HOMOLOGATION AUTOMOBILE

TECHNICAL REPORT

No.:LCA 54 327 004 1

Inspection concerning the

ANCHORAGES FOR MOTOR-VEHICLE SAFETY BELTS

performed according to the Directive of the Council of the European Communities

No. **76/115/EEC**

Seat type: **503**
Vehicle: **M1/N1**
Manufacturer of seats: **F.A.S.P. Tappezzeria**
Via Golgi, 27
I - 25064 Gussago (BS)

Index:

1. General	Page 2
2. Inspection and their results	Page 4
3. Evaluation of test results	Page 6
4. Statement of compliance	Page 7
5. Annex (beginning with an index)	

A reproduction of this report and its annexes, except in full, is prohibited without the written permission of Luxcontrol s.a.

G. 1.

$\overline{DR} = 315 + 1,8 \cdot S = 702$

$\overline{BR} = 260 + S = 475$

$S = 215$

$\alpha_{2/3} = 30^\circ$

$\alpha_{1/4} = 36^\circ$

$\alpha = 10^\circ$

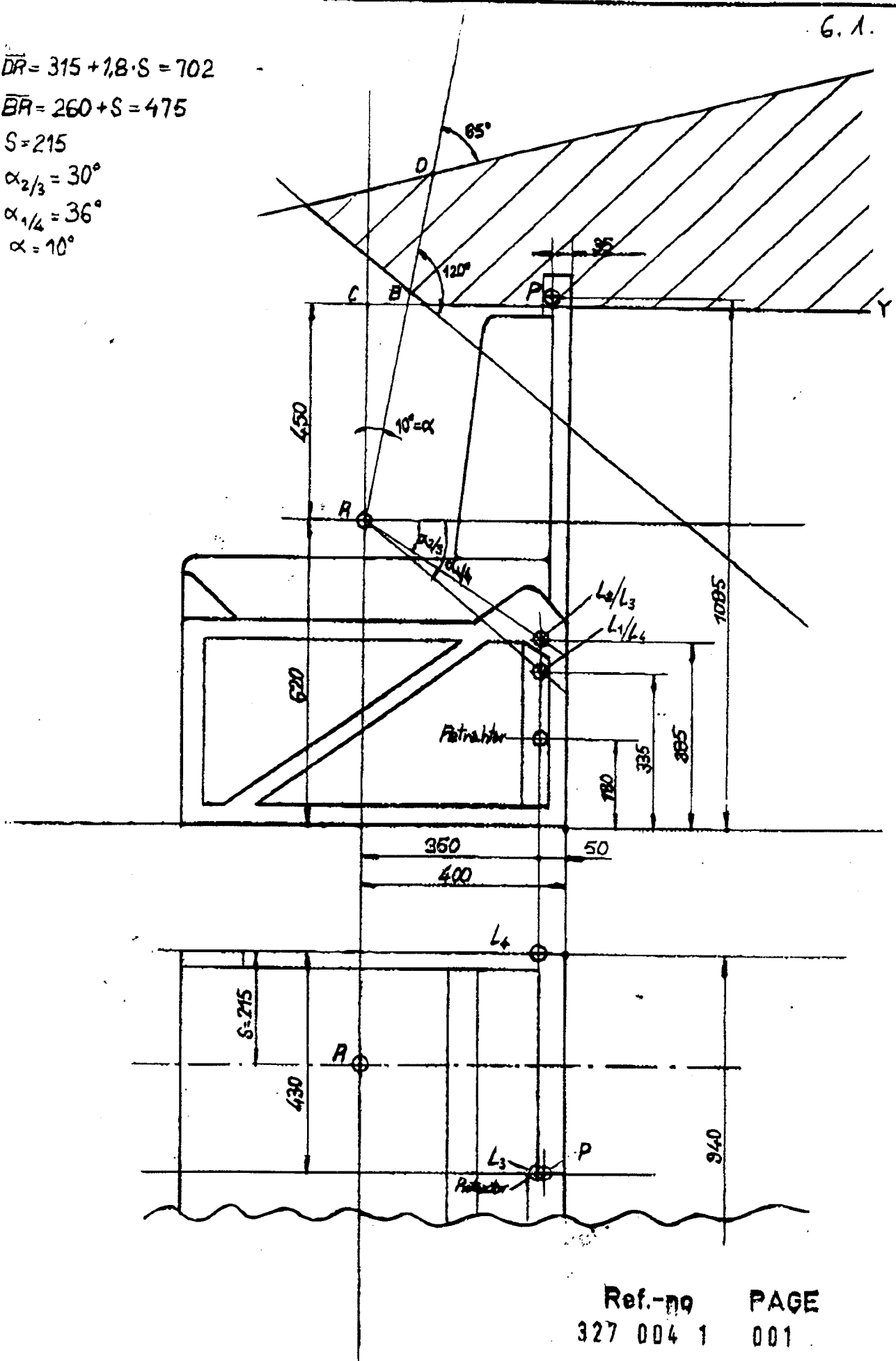

6.2

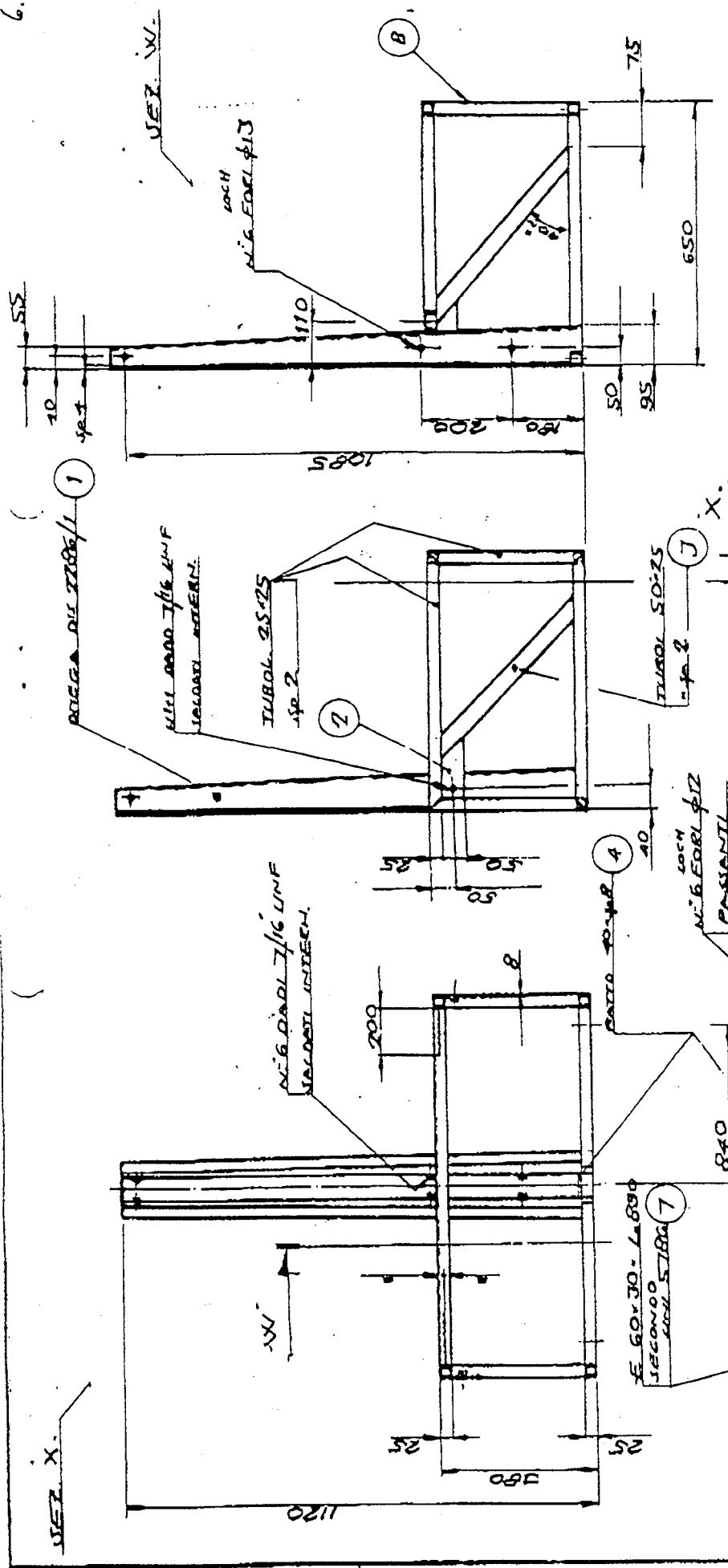

PIZZA DI TUBO 1

9	VERGHE IN ACCIAIO	2	PM 378
8	VERGHE IN ACCIAIO	4	PM 378
7	VERGHE IN ACCIAIO	1	PM 378
6	VERGHE IN ACCIAIO	2	PM 378
5	VERGHE IN ACCIAIO	2	PM 378
4	VERGHE IN ACCIAIO	1	PM 378
3	VERGHE IN ACCIAIO	2	PM 378
2	VERGHE IN ACCIAIO	2	PM 378
1	VERGHE IN ACCIAIO	1	PM 378

PIZZA DI TUBO 1

9	VERGHE IN ACCIAIO	2	PM 378
8	VERGHE IN ACCIAIO	4	PM 378
7	VERGHE IN ACCIAIO	1	PM 378
6	VERGHE IN ACCIAIO	2	PM 378
5	VERGHE IN ACCIAIO	2	PM 378
4	VERGHE IN ACCIAIO	1	PM 378
3	VERGHE IN ACCIAIO	2	PM 378
2	VERGHE IN ACCIAIO	2	PM 378
1	VERGHE IN ACCIAIO	1	PM 378

PIZZA DI TUBO 1

9	VERGHE IN ACCIAIO	2	PM 378
8	VERGHE IN ACCIAIO	4	PM 378
7	VERGHE IN ACCIAIO	1	PM 378
6	VERGHE IN ACCIAIO	2	PM 378
5	VERGHE IN ACCIAIO	2	PM 378
4	VERGHE IN ACCIAIO	1	PM 378
3	VERGHE IN ACCIAIO	2	PM 378
2	VERGHE IN ACCIAIO	2	PM 378
1	VERGHE IN ACCIAIO	1	PM 378

PIZZA DI TUBO 1

9	VERGHE IN ACCIAIO	2	PM 378
8	VERGHE IN ACCIAIO	4	PM 378
7	VERGHE IN ACCIAIO	1	PM 378
6	VERGHE IN ACCIAIO	2	PM 378
5	VERGHE IN ACCIAIO	2	PM 378
4	VERGHE IN ACCIAIO	1	PM 378
3	VERGHE IN ACCIAIO	2	PM 378
2	VERGHE IN ACCIAIO	2	PM 378
1	VERGHE IN ACCIAIO	1	PM 378

PIZZA DI TUBO 1

9	VERGHE IN ACCIAIO	2	PM 378
8	VERGHE IN ACCIAIO	4	PM 378
7	VERGHE IN ACCIAIO	1	PM 378
6	VERGHE IN ACCIAIO	2	PM 378
5	VERGHE IN ACCIAIO	2	PM 378
4	VERGHE IN ACCIAIO	1	PM 378
3	VERGHE IN ACCIAIO	2	PM 378
2	VERGHE IN ACCIAIO	2	PM 378
1	VERGHE IN ACCIAIO	1	PM 378

Ref.-no PAGE
327 004 1 002

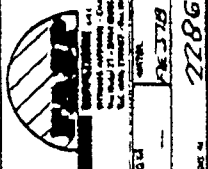

N. 6 FORI Ø10
PASSANTI

2286

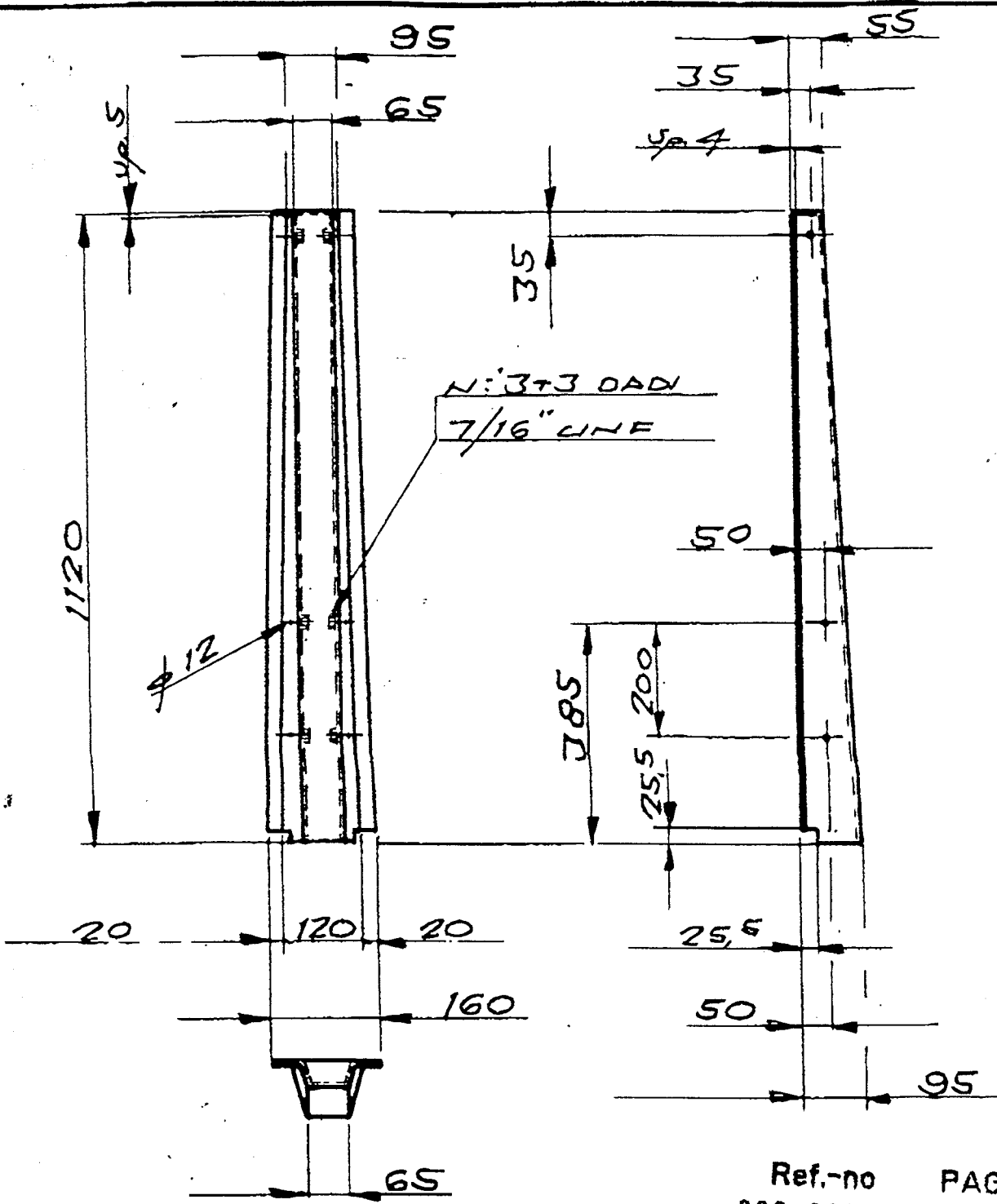

6.3.

Ref.-no PAGE
327 004 1 003

POS.	DENOMINAZIONE	Q.TA	DIS. N.	MATERIALE E NOTE	PESO UNIT.	
N.	MODIFICHE	ESEGUITA	DATA			
1						
2						
3						
DESCRIZIONE				Q.TA	MATER.	TRATT. VERN.
STÄHLHOLM FÜR UNTERGESTELL SITZBANK 503 MIT 3. PUNKT SICHERHEITSGURT				1	FE 37B	NERO
DATA	SCALA	DISEGN.	VISTO	DIS. N. 2286/1		
26.5.94	1:10	MASSI	—	FOGLIO 1		



* LCA 54 327 004 1 *FASP*503*76/115* --

2. Inspection and their results

2.1. Version of the tested vehicle

Following version has been used for testing (if not stated in part 1.2.2. of this report):

Not applicable

2.2. Inspection items

2.2.1. Test vehicle:

Rigid platform on which the seats have been fixed reproducing the loading geometry of the systems with which the vehicle is equipped.

2.2.2. Dimensional check:

An x-y-z measuring device was used to dimensionally check the location of all H-points, as well as the effective belt anchorages regarding their zone compliance.

2.2.3. Strength tests:

The loads were applied using a device comprising a series of hydraulic rams, to apply the safety belt anchorage loads.

2.3. Test results:

2.3.1. H-point location:

The location of the H-points were measured and found to conform with the 50 mm x 50 mm tolerance zones for their respective R-points as stated by the vehicle manufacturer.

TÜV BAYERN SACHSEN E.V.
Institut für Fahrzeugtechnik

Deimlerstraße 11
D-85748 Garching

Telefon 089/329557-0
Telefax 089/329557-44



Institut für Fahrzeugtechnik
Zentralabteilung Gesamtfahrzeug

Seite 1

Technisches Gutachten

Nr. 372-001-95-FBFS

über

Verankerungen für Sicherheitsgurte

Hersteller: FASP Tappezzeria srl
Via Golgi 27
I-25064 Gussago (BS)

Typ: 503

Dieses Gutachten dient als Arbeitsunterlage für den amtlich anerkannten Sachverständigen für den Kraftfahrzeugverkehr bei Fahrzeugabnahmen nach §21 StVZO.

TÜV BAYERN SACHSEN E.V.
Institut für Fahrzeugtechnik

Daimlerstraße 11
D-85748 Garching

Telefon 0 89 / 32 95 57 - 0
Telefax 0 89 / 32 95 57 - 44



Gutachten-Nr. 372-001-95-FBFS.
über Verankerungen für Sicherheitsgurte
der Firma FASP Tappezzeria, Gussago

Seite 2

I. Allgemeines

- 1.1. Antragsteller: FASP Tappezzeria srl
Via Golgi 27
I-25064 Gussago (BS)
- 1.2. Hersteller: FASP Tappezzeria srl
Via Golgi 27
I-25064 Gussago (BS)
- 1.3. Art: An einer Stahlrahmenkonstruktion angebrachte Verankerungspunkte für Sicherheitsgurte, überbaut von einer Sitzliegebank mit Polstern
- 1.4. Typ: 503
- 1.5. Ausführungen: nur eine
- 1.6. Wahlweise Ausrüstung: entfällt
- 1.7. Gewicht: ca. 45 kg, einschließlich Sitzbank
- 1.8. Werkstoff: St 37
- 1.9. Sonstiges:
Anzahl der Sitzplätze: 2 je Sitzbank



- Page 3-

* LCA 54 327 004 1 *FASP*503*76/115* --

1. General

1.1. Test Provisions

The inspection was carried out according to the requirements of the Council Directive of the European Communities 76/115/EEC including all amendments up to 96/38/EC of June 17, 1996 (except of point 4.3. concerning the minimum number of seat belts to be provided).

1.2. General

This report describes the test of the strength of the seat itself only. The verification concerning the seat installation and the strength of the vehicle chassis in relation with the seat belt system has still to be made.

1.3. Information concerning the seat

1.3.1. Type

503

1.3.2. Brief description of seat type

- *Double seat bench*
- *Welded steel construction*
- *Fixing of seat on floor: see information document*

1.3.3. Brief description of seat belt anchorages

- *3 point seat belt with retractor (Ar)*
- *anchorage points: see information document*

1.4. Information concerning the vehicle

1.4.1. Brief description of vehicle in which the seat can be mounted:

Vehicle category: M1/N1 (rear seats)



- Page 7-

* LCA 54 327 004 1 *FASP*503*76/115* --

4. **Statement of compliance**

The inspection items and measurements carried out have shown the compliance of the vehicle type described in this report and the attached Annex with the requirements of the Council Directive of the European Communities 76/115/EEC including all amendments up to 96/38/EC of June 17, 1996 (except of point 4.3. concerning the minimum number of seat belts to be provided).

Esch/Alzette, July 27, 2001

Luxcontrol s.a.
Service Homologation-Automobile

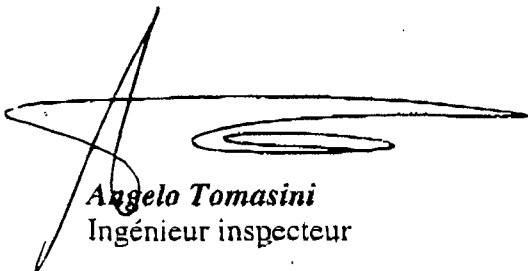

Angelo Tomasini
Ingénieur inspecteur

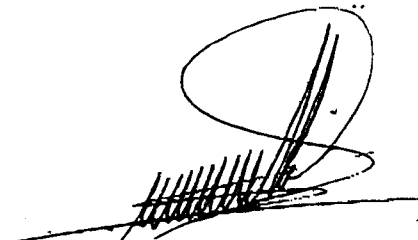

Patrizio Vinciarelli
Ingénieur inspecteur

Annex



* LCA 54 327 004 1 *FASP*503*76/115* --

3. **Evaluation of test results**

3.1. **Variants and equipment covered**

The test results carried out cover the following variants of the seat:

- *Seat as stated in manufacturer's document*

3.2. **Remarks**

3.2.1. not applicable



* LCA 54 327 004 I *FASP*503*76/115* --

2.3.2. Quantity and design of safety belt anchorages:

3 point seat belt with retractor (Ar)

2.3.3. Strength tests:

Loads were applied as rapidly as possible, in accordance with the Directive. All anchorages sustained the test loads simultaneously for the required time, without rupture. After test, the minimum spacings for the effective lower belt anchorages and the location requirements for the effective upper belt anchorages were still in compliance with the Directive.

2.4. **Remarks**

2.3.1. General:

The inspection results are only applicable to the seat itself. The strength of the vehicle chassis to which the seat has to be fixed has not been tested.

2.4. **Test facilities**

All measuring and test equipment used to carry out the inspections is in accordance with the EEC-Directive stated in 1.1. of this report and with EN45001.